

CORNER RECORD

Document Number 1997-SS&TT
County of MERCED, California

City of _____
Brief Legal Description LOT 9 OF BLOCK 7 AS SHOWN ON "MAP OF THE TOWN OF CRESSEY", 4 O.P. 36, MERCED COUNTY RECORDS

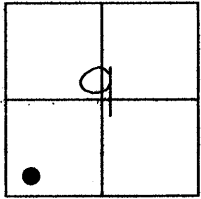

CORNER TYPE
Government Corner Control
Meander Property
Rancho Other
Date of Survey 03/17/2009

COORDINATES(Optional)
N. _____
E. _____
Zone _____ NAD27 NAD83
NAD83 Epoch _____
Elev. _____
Vert Datum: NGVD29 NAVD88
Meas. Units: Metric Imperial

Corner - Left as found Found and tagged Established Reestablished Rebuilt

Identification and type of corner found: Evidence used to identify or procedure used to establish or reestablish the corner:
See Page 2 of 2

A description of the physical condition of the monument as found and as set or reset:
See Page 2 of 2

SURVEYOR'S STATEMENT

This Corner Record was prepared by me or under my direction in conformance with the land Surveyors' Act on MARCH 18th, 2009.
Signed Duane J. Andrews P.L.S. No.: 4052

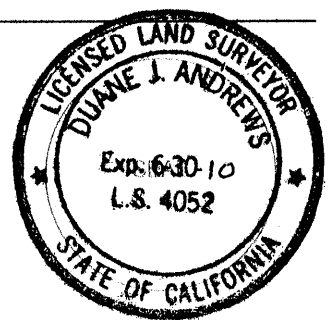

COUNTY SURVEYOR'S STATEMENT

This Corner Record was received April 8, 2009 and examined and filed April 9, 2009.
Signed J. Steve Reichmuth P.L.S. or R.C.E. No.: 4895
Title Dep. County Surveyor
County Surveyor's Comment _____

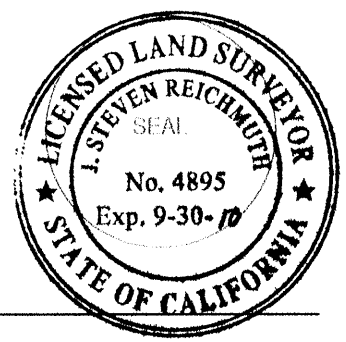



SCALE: 1" = 80'



DID NOT SET TAG,
POST HAS NAIL.
I.P. FOR LOCATOR
SET AT NORTH
CORNER OF POST

THIRD STREET

SECOND STREET

CRESSEY STREET

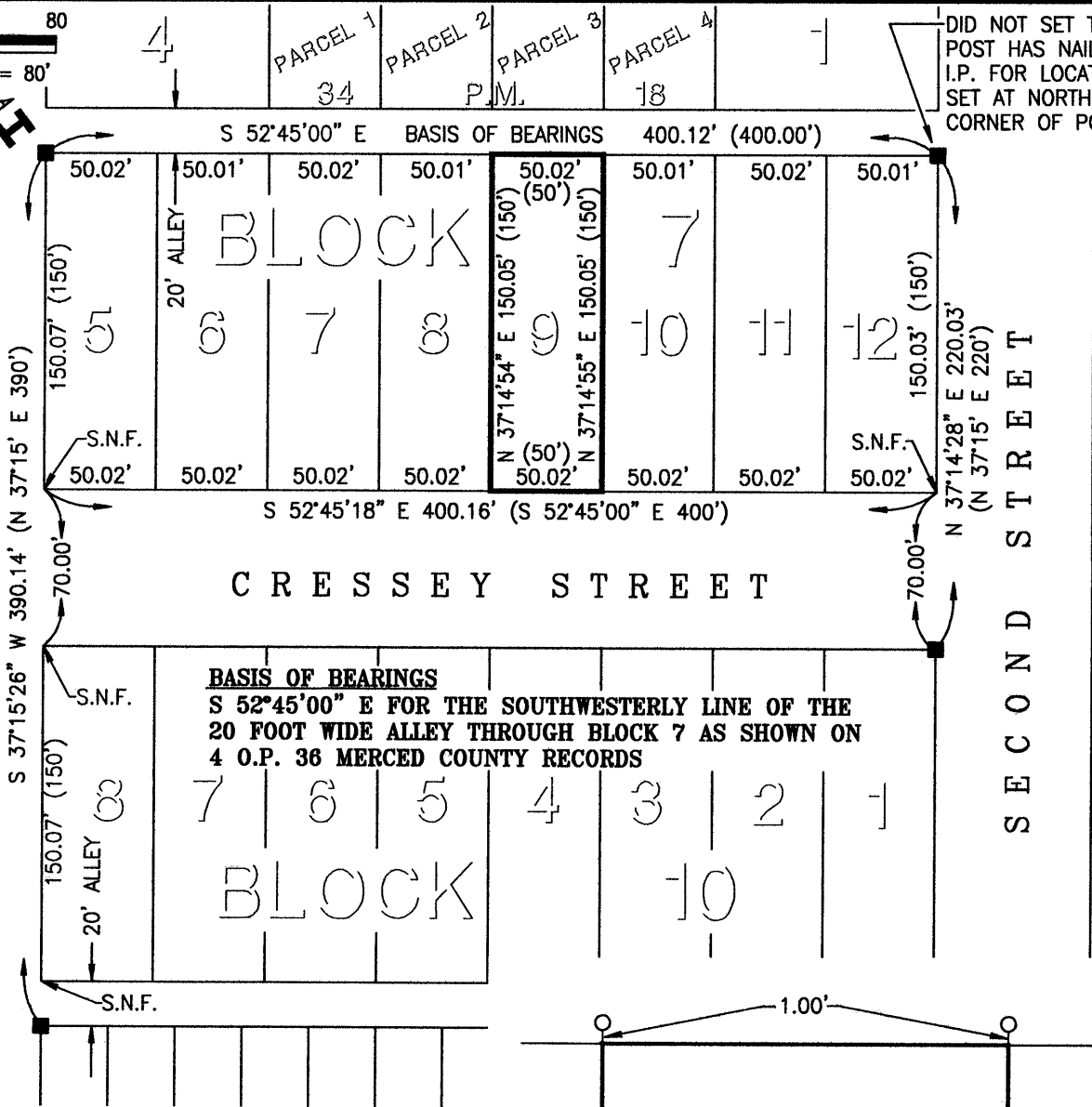

LEGEND

- Found 3x3 redwood post, per 4 O.P. 36. Set brass tag, L.S. 4052, in center of post. Set open 3/4" iron pipe at south corner of post for magnetic locator use. Unless otherwise noted.
- Set 3/4" Iron Pipe, L.S. 4052, as witness to lot corners on line with the northwesterly or southeasterly lines of Lot 9 (distance shown in detail at bottom of page).
- () Record Information per 4 O.P. 36

S.N.F. Searched Nothing Found

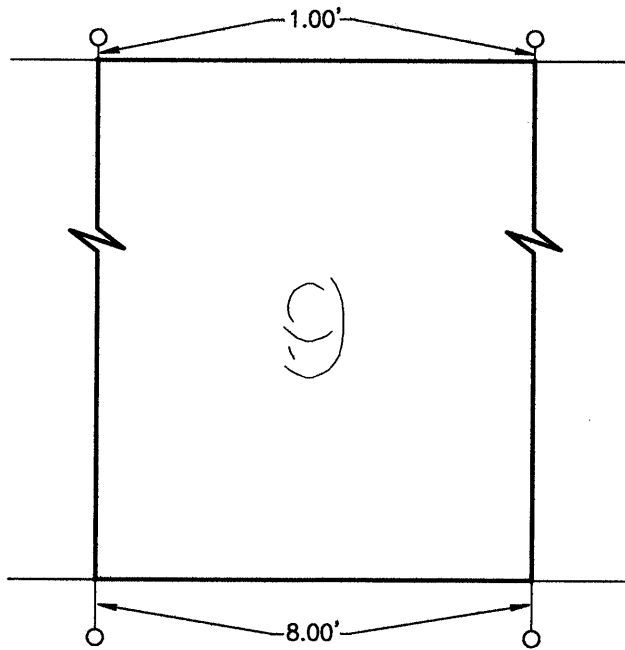

WITNESS CORNER DETAIL

NOT TO SCALE